

THIS DRAWING IS UNPUBLISHED. RELEASED FOR PUBLICATION
 © COPYRIGHT - By - ALL RIGHTS RESERVED.

LOC	DIST	REVISIONS			
P	LTR	DESCRIPTION	DATE	DWN	APVD
J	-	A	RELEASED	15MAY2014	H.F A.K

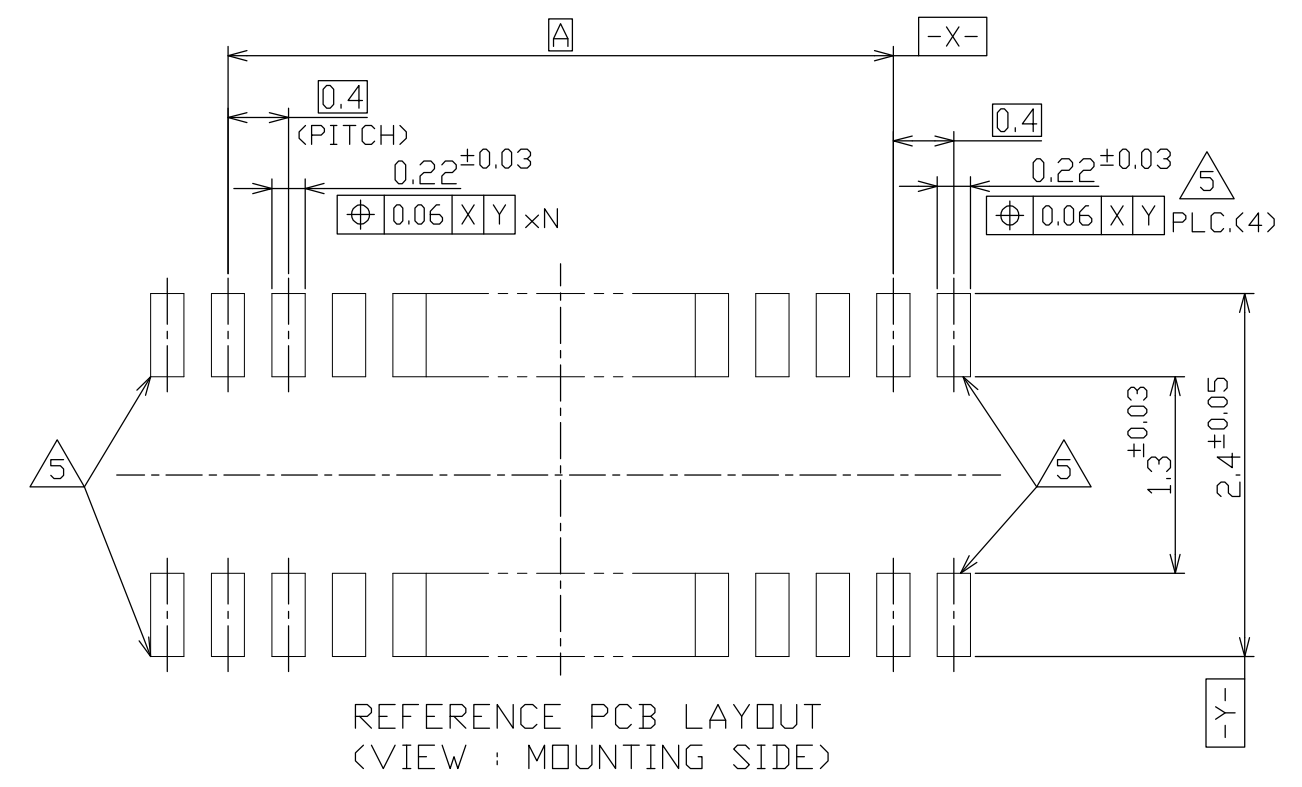
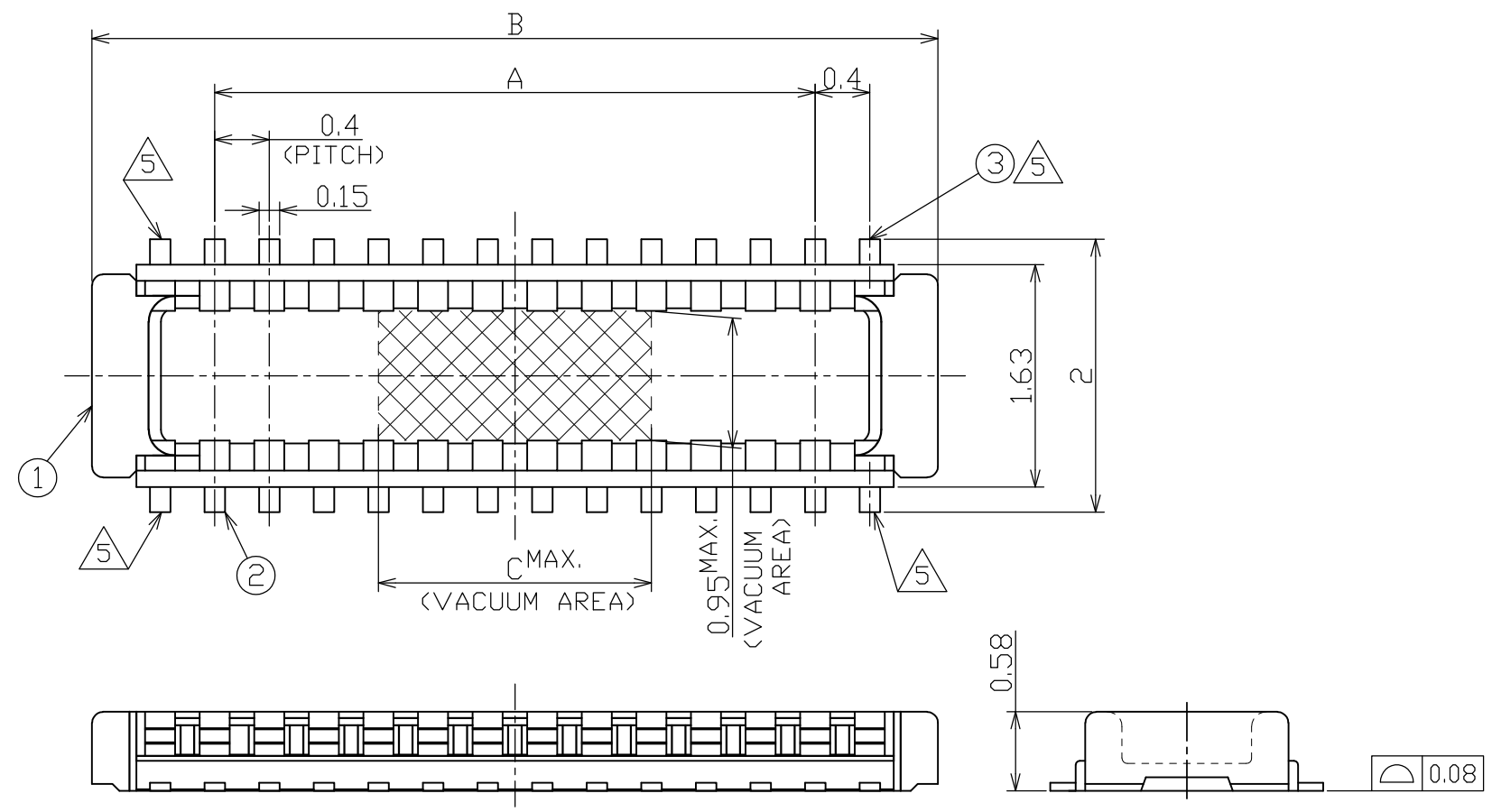

REFERENCE PCB LAYOUT
(VIEW : MOUNTING SIDE)

- △ MATERIAL REFER TO THE TABLE.
- △ FINISH REFER TO THE TABLE.
- 3. MATING CONNECTOR :

STACK HEIGHT	PART NUMBER	
	PLUG	RECEPTACLE
0.7	*-2260336-*	*-2822367-*

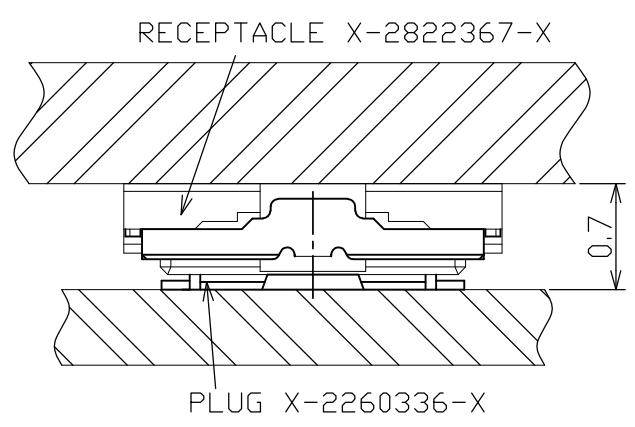

- △ GENERAL TOLERANCES ±0.1, ±3'
- △ 4 CORNERS PIN IS SOLDER PEG (NOT SIGNAL CONTACT) FOR SOLDERING AND PEAL-STRENGTH ASSISTANCE.
- △ THIS DIMENSION IS THE DISTANCE FROM THE EMBOSS TAPE SURFACE TO CONNECTOR PICK UP & PLACE SURFACE.

5.0	11.4	9.6	50	5-2260336-0
5.0	9.4	7.6	40	4-2260336-0
5.0	7.4	5.6	30	3-2260336-0
2.0	6.2	4.4	24	2-2260336-4
2.0	3.4	1.6	10	1-2260336-0
C	B	A	Pos.	PART NUMBER
DIMENSIONS				

Ni UNDER PL Au PL.(TINE AREA)	COPPER ALLOY	SOLDER PEG	③
Ni UNDER PL Au PL.(CONTACT AREA) Au PL.(TINE AREA)	COPPER ALLOY	PLUG CONTACT	②
	THERMO PLASTIC	PLUG HOUSING	①
△ FINISH	△ MATERIAL	NAME	ITEM NO.

THIS DRAWING IS A CONTROLLED DOCUMENT.

DWN	H.FUKUZAKI	10JUN2013
CHK	A.KUBO	10JUN2013
APVD	A.KUBO	10JUN2013
PRODUCT SPEC		
APPLICATION SPEC		
WEIGHT		

STE TE Connectivity

0.4mm PITCH STACKING CONNECTOR
PLUG ASSEMBLY

SIZE	CAGE CODE	DRAWING NO	RESTRICTED TO
A3	00779	C-2260336	-

CUSTOMER DRAWING SCALE 20:1 SHEET 1 OF 2 REV A

THIS DRAWING IS UNPUBLISHED. RELEASED FOR PUBLICATION
 © COPYRIGHT - By - ALL RIGHTS RESERVED.

LOC	DIST	REVISIONS					
		P	LTR	DESCRIPTION	DATE	DWN	APVD
J	-	-	-	SEE SHEET 1	-	-	-

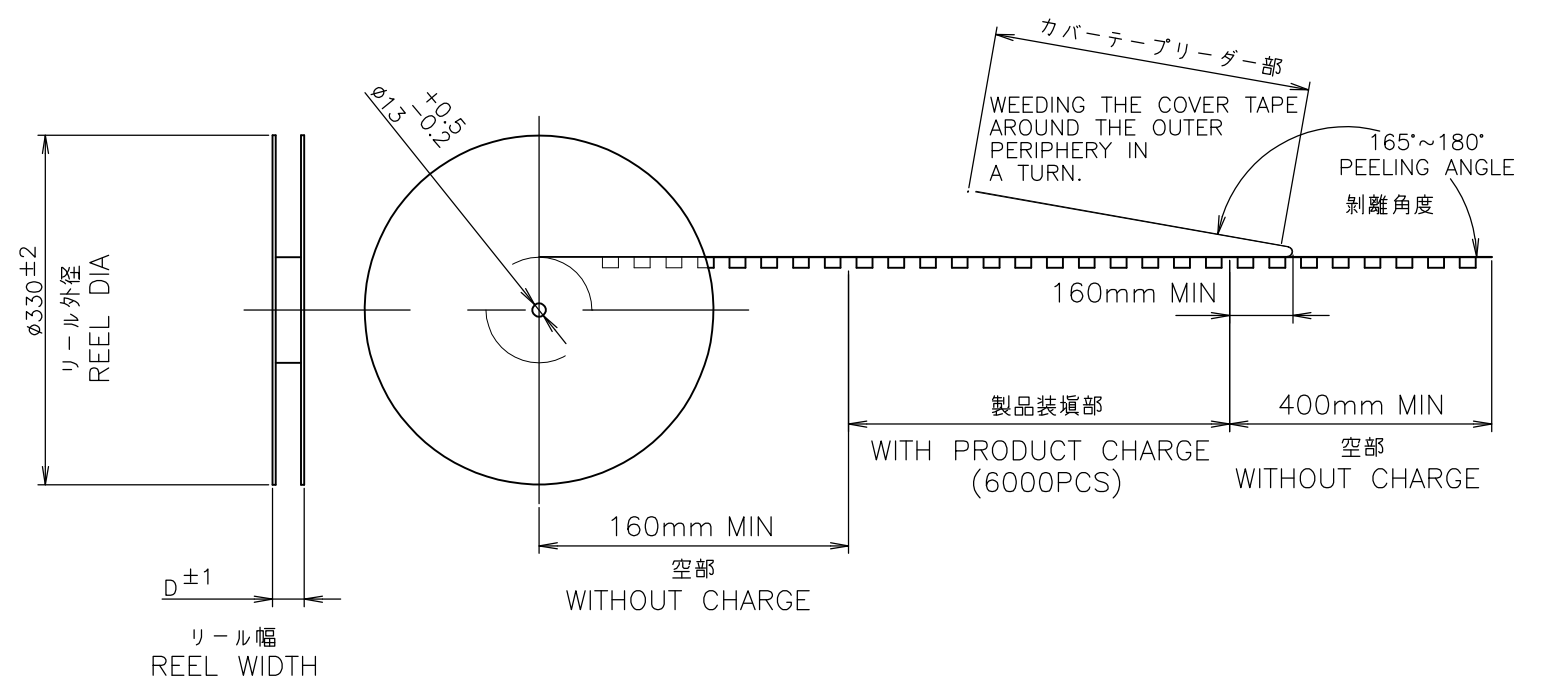
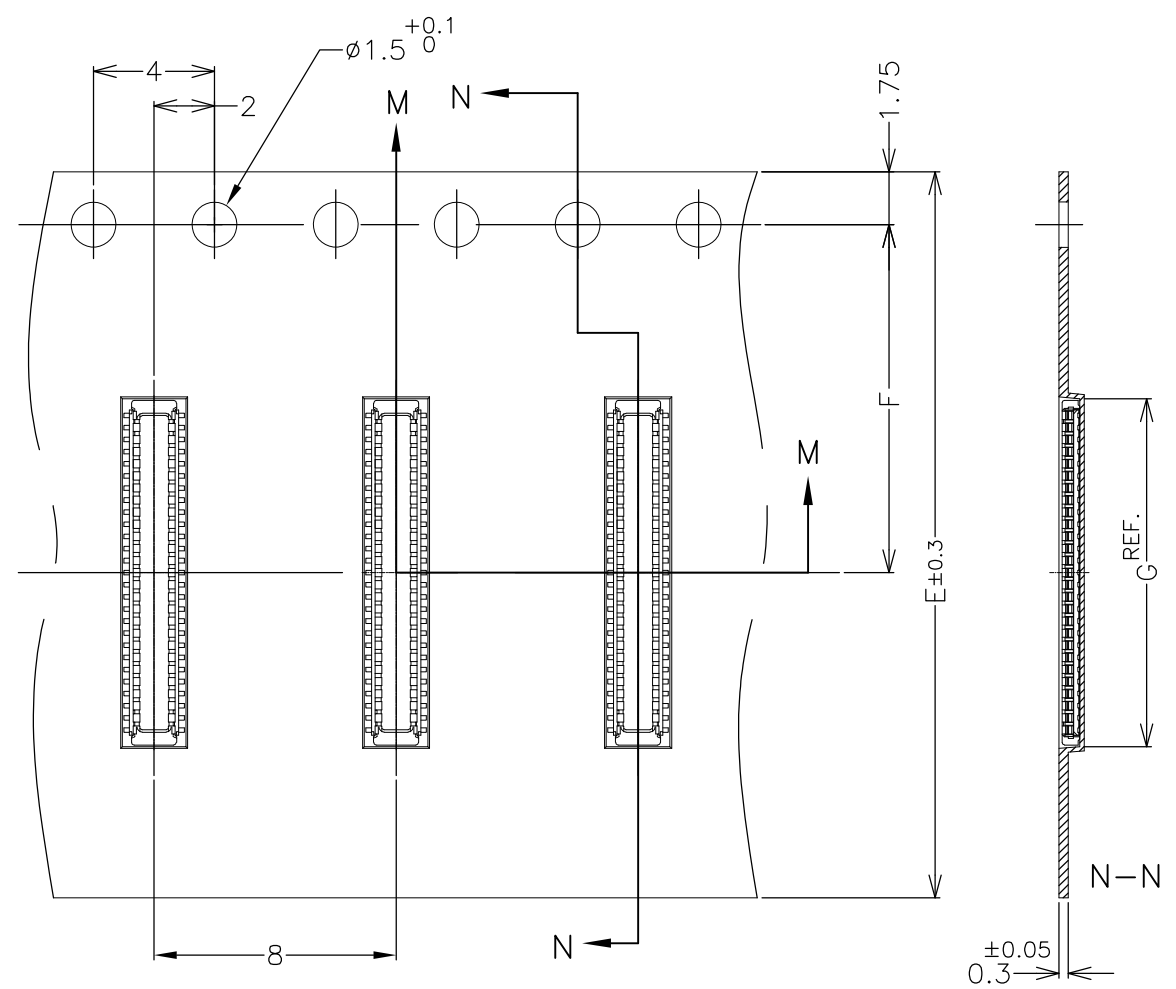

11.5	11.5	24.0	29.4	50
9.5	11.5	24.0	29.4	40
7.5	7.5	16.0	21.4	30
6.3	7.5	16.0	21.4	24
3.5	5.5	12.0	17.4	10
G	F	E	D	Pos.

DIMENSIONS

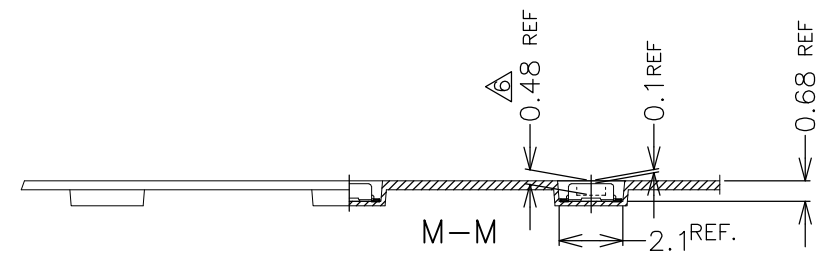

THIS DRAWING IS A CONTROLLED DOCUMENT.		DWN		STE TE Connectivity	
DIMENSIONS: mm		CHK			
TOLERANCES UNLESS OTHERWISE SPECIFIED:		APVD		NAME	
0 PLC \pm		PRODUCT SPEC		0.4mm PITCH STACKING CONNECTOR PLUG ASSEMBLY	
1 PLC \pm		APPLICATION SPEC		SIZE CAGE CODE DRAWING NO RESTRICTED TO	
2 PLC \pm		WEIGHT		A3 00779 C-2260336	
3 PLC \pm		CUSTOMER DRAWING		SCALE NTS SHEET 2 OF 2 REV A	
4 PLC \pm					
ANGLES \pm					
FINISH \triangle					